

INSTALLATION INSTRUCTIONS

Lever on Short Plate

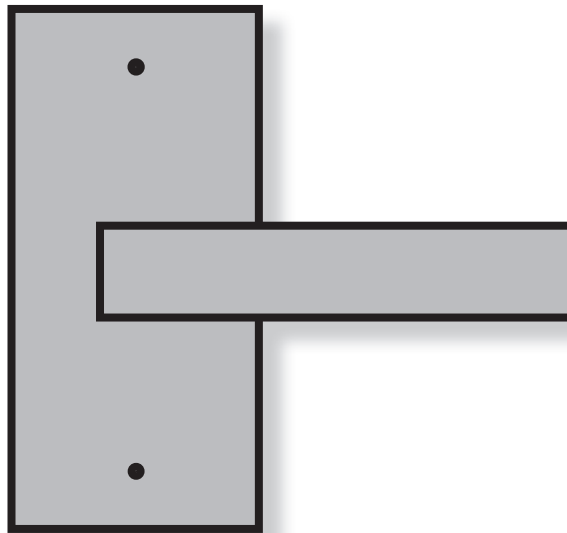

Tubular Latch

ALL FUNCTIONS

INSTALLATION INSTRUCTIONS

March 2020

Series

FAP MAP

MSP ESP

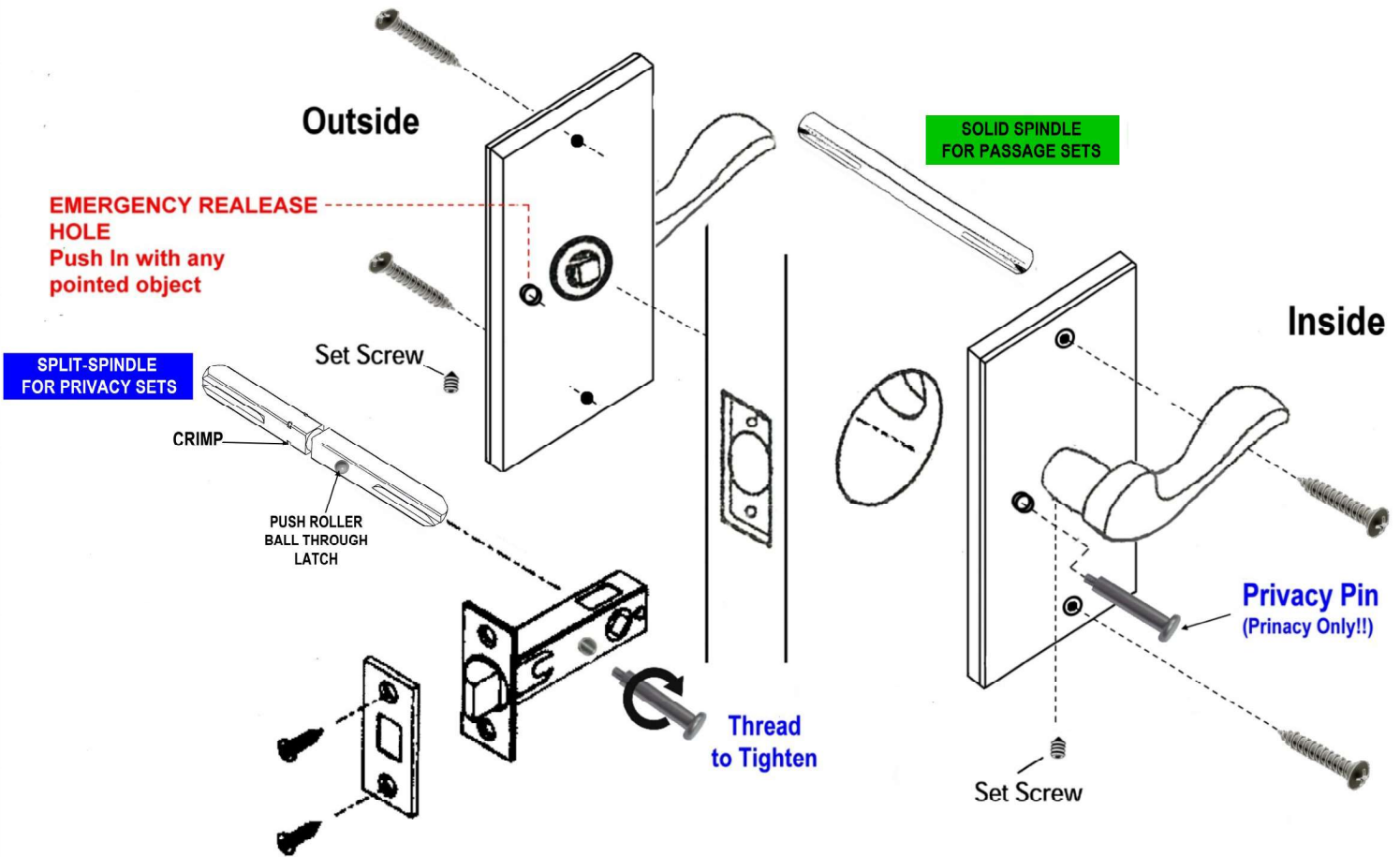

PRIVACY SPLIT-SPINDLE INSTALLATION - Please Read Carefully !!

1. Install Split-Spindle with Roller Ball going through latch until it stops.
2. Spindle is now in Self- Aligned position.
3. Install Outside adaptor and tighten set screws firmly.
4. Thread on PRIVACY PIN and test operation.

PRIVACY MUST HAVE SPLIT SPINDLE

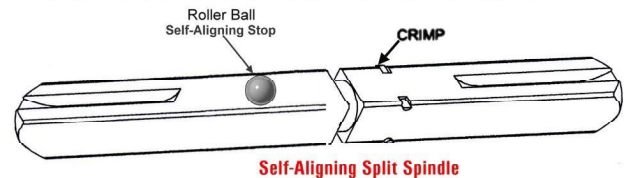

TEMPLATE

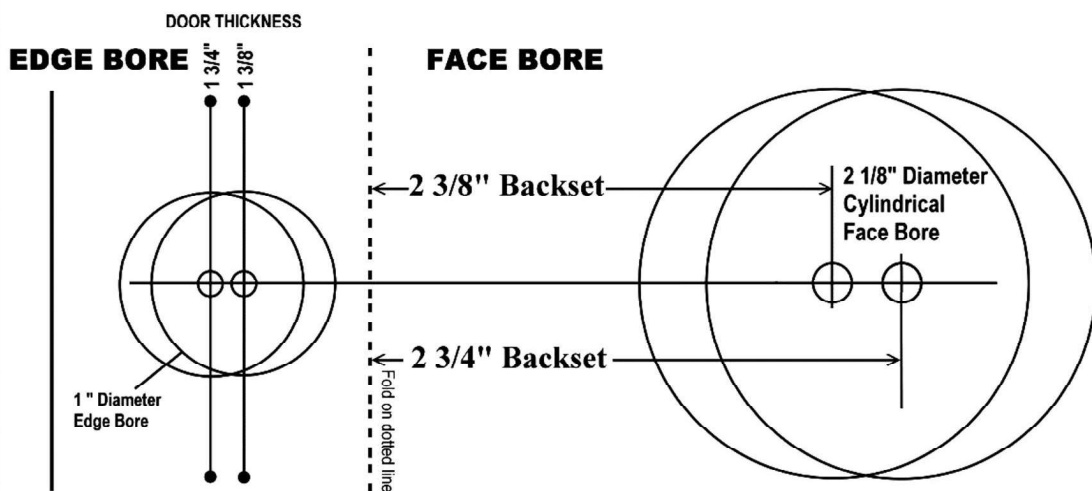

**NOT TO SCALE
CONFIRM ALL
MEASUREMENTS
ON SITE!!!**

INSTALLATION INSTRUCTIONS

March 2020

Series

FAP MAP

MSP ESP

FACE PLATE

POINT NO. 3
(Screw mounting points)

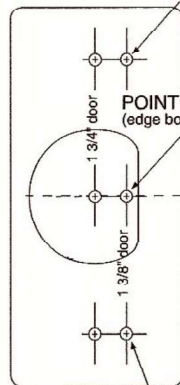

POINT NO. 4
(Screw mounting points)

IMPORTANT:
READ ALL INSTRUCTIONS CAREFULLY
BEFORE PREPARING DOOR

PASSAGE LATCH TEMPLATE

2-3/8\"/>

POINT NO. 2 (face bore)

2-3/4\"/>

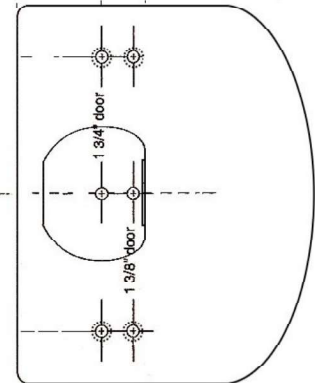

Fold on dotted line - Lay over edge of door.

Fold on dotted line - Lay over edge of door.

Passage Strike

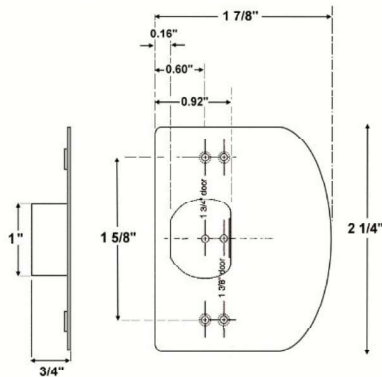

Passage Latch & Strike

Passage Latch

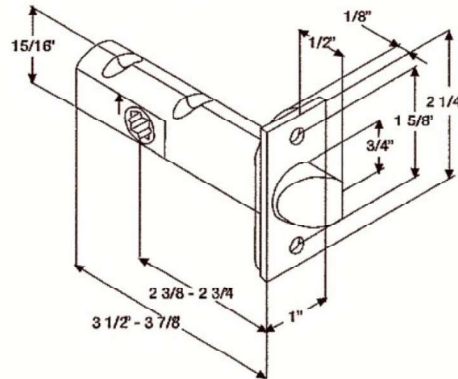

TOOLS REQUIRED:

Drill, 1" dia. bit, 5/8" dia. bit, 1/8" dia. bit,
Center Punch, Chisel, Hammer, Phillips Screwdriver.

**BE SURE TO READ ALL INSTRUCTIONS
BEFORE PREPARING DOOR.**

1. Position Template

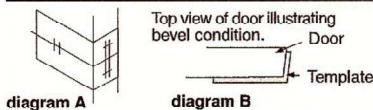

Determine latch backset (2-3/8" or 2-3/4"). Fold enclosed template on dotted line and locate on door at desired height (diagram A). If door is bevelled (see diagram B), place folded edge on low side of bevel as shown above.

2. Mark Door

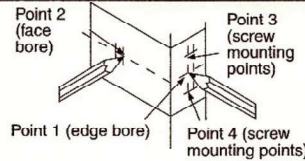

Mark door at points No. 1, No. 2, No. 3, and No. 4 and center punch for drilling.

3. Drill Edge Bore

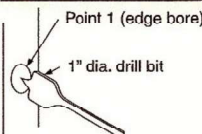

Drill 1" dia. hole.
2-3/8" backset.... drill 3-5/8" deep.
2-3/4" backset.... drill 4" deep.

4. Drill Face Bore

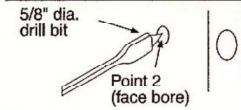

Keep drill perpendicular to door surface and drill through.
Note for wood doors: to avoid splintering, drill a centering hole through the door, then drill face bore from both sides.

5. Position Faceplate

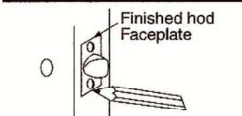

Position finished faceplate over latch. Slide latch into edge bore. Check that screw mounting points are centered before tracing the outline of the finished faceplate.

6. Chisel Mortise



Remove latch. Drill 1/8" screw holes. Chisel out mortise 5/32" deep.

7. Insert Latch

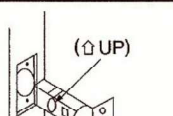

With "UP" side up, slide latch into edge bore.

8. Attach Faceplate

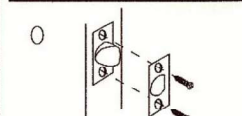

Rotate head so angled side is toward strike when door closes. Position finished faceplate and fasten with two screws.

9. Install Strike

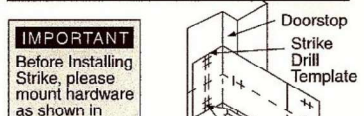

IMPORTANT
Before Installing Strike, please mount hardware as shown in drawing above.

Using strike template, mark jamb, drill screw holes and chisel mortise at proper location. Install strike.

NOTE: Check to ensure face plate does not restrict free movement of the latch head. Install trim.

USE ONLY ORIGINAL TEMPLATE FOR MARKING DOORS

Installation Instructions Function 30 Single (Half) Dummy

Feb 2022

BE SURE TO READ ALL INSTRUCTIONS BEFORE PREPARING DOOR.

Determine Backset

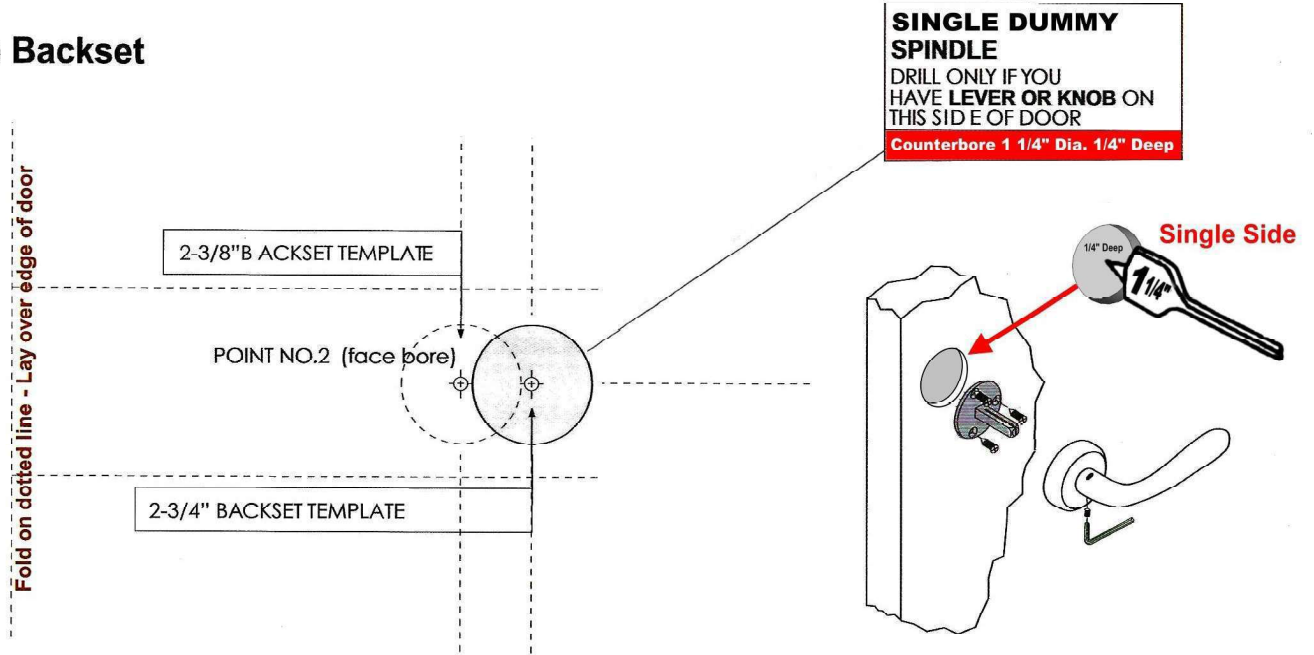

Installation Instructions Function 32 Double (Full) Dummy

Feb 2022

BE SURE TO READ ALL INSTRUCTIONS BEFORE PREPARING DOOR.

Determine Backset

